

Specification



ZE5500V-2250

ZERES 5 Series: Electric with Integrated Hydraulics



Clamping Unit		ZE5500 V
Clamping Force	kN	5500
	US Tons	618
Mold Opening Stroke	mm	900
	in.	35.43
Minimum Mold Height	mm	400
	in.	15.75
Maximum Mold Height	mm	880
	in.	34.65
Maximum Daylight	mm	1780
	in.	70.08
Distance Between Tie-Bars (HXV)	mm	970x970
	in.	38.19x38.19
Platen Dimensions (HXV)	mm	1320x1320
	in.	51.97x51.97
Minimum Mold Size	mm	630x630
	in.	24.8x24.8
Ejector Stroke	mm	180
	in.	7.09
Ejector Force	kN	154
	US Tons	17

Specification



ZE5500V-2250

ZERES 5 Series: Electric with Integrated Hydraulics

Injection Unit		2250		
Screw & Barrel Designation		A	B	C
Screw Diameter	mm	65	70	80
	in.	2.56	2.76	3.15
Screw L/D Ratio	L/D	21.5	20	17.5
Injection Volume (Theoretical)	cm ³	1068	1239	1618
	cu.in.	65.17	75.61	98.74
Injection Weight (PS)	g	972	1127	1472
	oz.	34.29	39.75	51.92
Injection Pressure	MPa	210	180	138
	psi	30458	26107	20015
Holding Pressure	MPa	190	162	124
	psi	27557	23496	17985
Screw Speed	rpm	240	240	240
Plasticizing Rate (GPPS)	g/s	62	71	88
	oz./s	2.19	2.50	3.10
Nozzle Contact Force	kN	85	85	85
	US Tons	10	10	10
Injection Unit		2250		
Injection Speed	mm/s	160		
	in./s	6.3		
Injection Rate (PS)	g/s	463	537	702
	oz./s	16.33	18.94	24.76
Injection Unit		2250h		
Injection Speed	mm/s	250		
	in./s	9.84		
Injection Rate (PS)	g/s	723	839	1097
	oz./s	25.50	29.59	38.70

Specification



ZE5500V-2250

ZERES 5 Series: Electric with Integrated Hydraulics

Other		
Connection Power	kW/A	2250:65/109 2250h:89/150
Heating Power	kW	36.1
Machine Dimension	m in.	8.48x2.29x2.50 334x90x98
Machine Weight	t lbs.	28.55 62942
Hopper Capacity	l gal	50 13
Oil Pressure	MPa psi	17.5 2538
Oil Flow	l/min gal/min	204 54
Oil Tank	l gal	284 75

***NOTE:**

1. Machine dimensions and weights are based on the international standard configuration and are for reference only. Any options or country specific requirements will affect this. Contact Absolute Haitian service department for machine specific information.
2. Power requirements are based on the international standard configuration and are for reference only. Any options or country specific requirements will affect this. Contact Absolute Haitian service department for machine specific information.

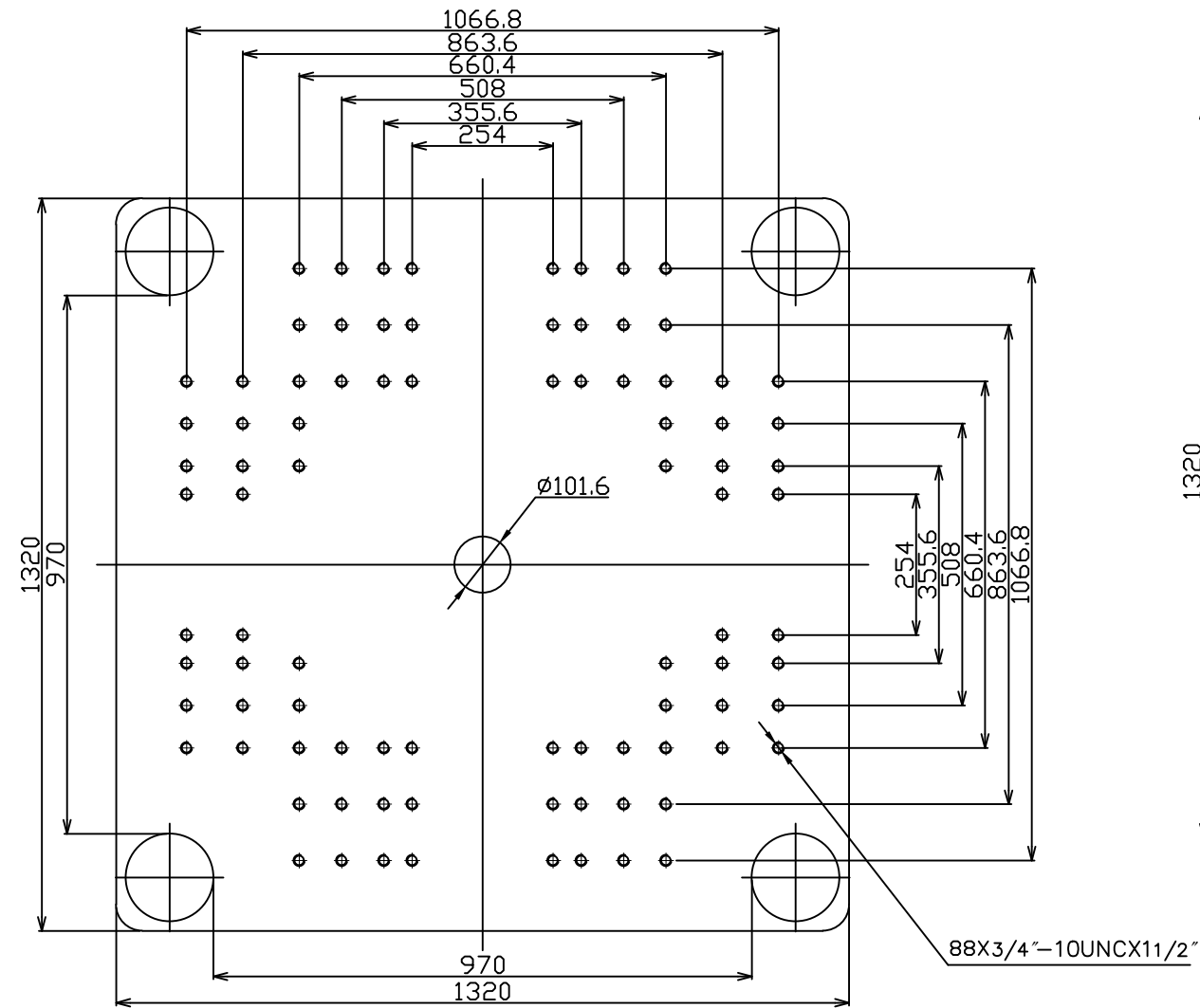

Fixed Platen

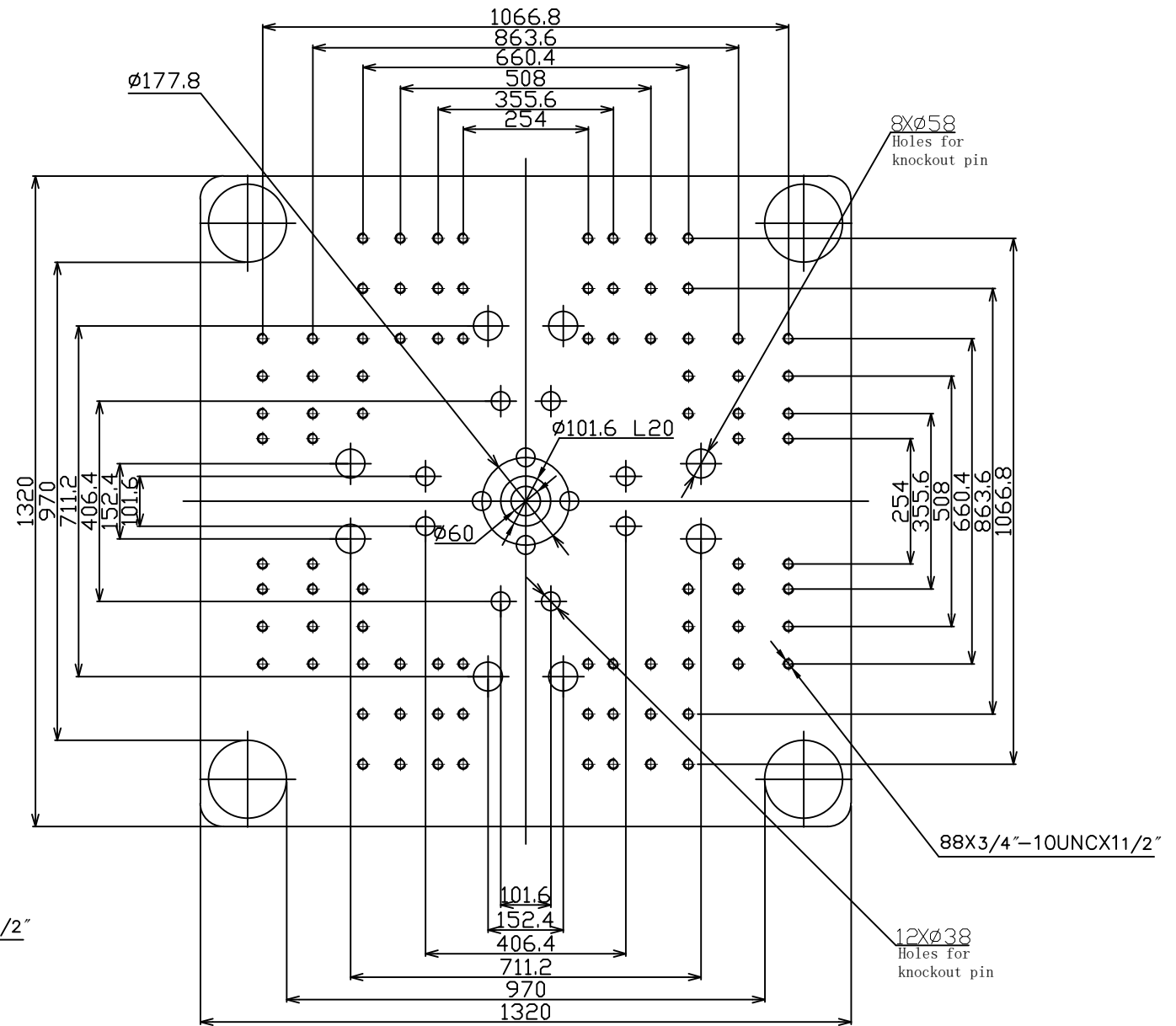

Moving Platen



Absolute Haitian Corporation
33 Southgate St. Worcester, MA
T: +1 508-792-4305
www.absolutehaitian.com

Title: ZE/VEV 5500 Fixed & Moving Platens Drawing

Machine Model: ZE/VEV 5500
Machine Serial Number:
Machine Tonnage:

Sheet: 1 of 1

Drawn By: Harry Date: 1/9/2024
Chkd By: LEON XIE Date: 1/9/2024

Revision	Date:	Drawing #:	NOT TO SCALE	Size: 11 X 17 "B"
Rev #: 1				Units: mm / [in]
Rev #: 2				Material:
Rev #: 3				Part:
Rev #: 4				Part:
Rev #: 5				Part:

PLEASE READ:

The designs on this drawing were validated using machine manufacturer's drawings and/or information supplied by Absolute or the customer. It is the responsibility of the customer to review and confirm that all dimensions are consistent with the application intended and in accordance with the facility requirements for space, part clearance, overhead clearance, or any other interference. By signing this document, the customer accepts full responsibility for this design and application.

Customer:

Customer Approval:
Authorized Signature

Notes:

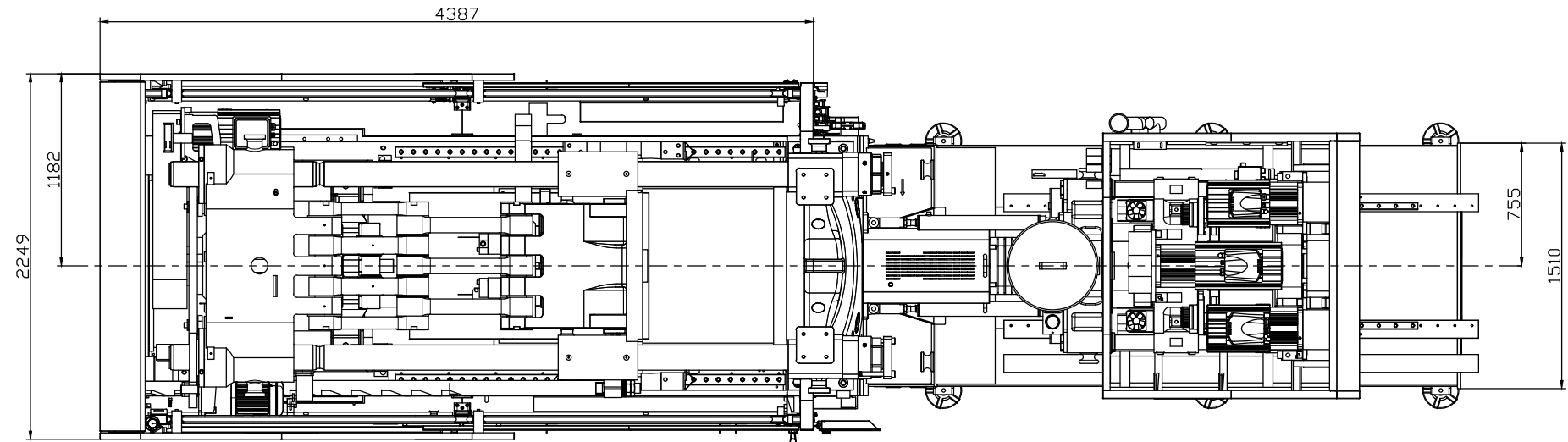
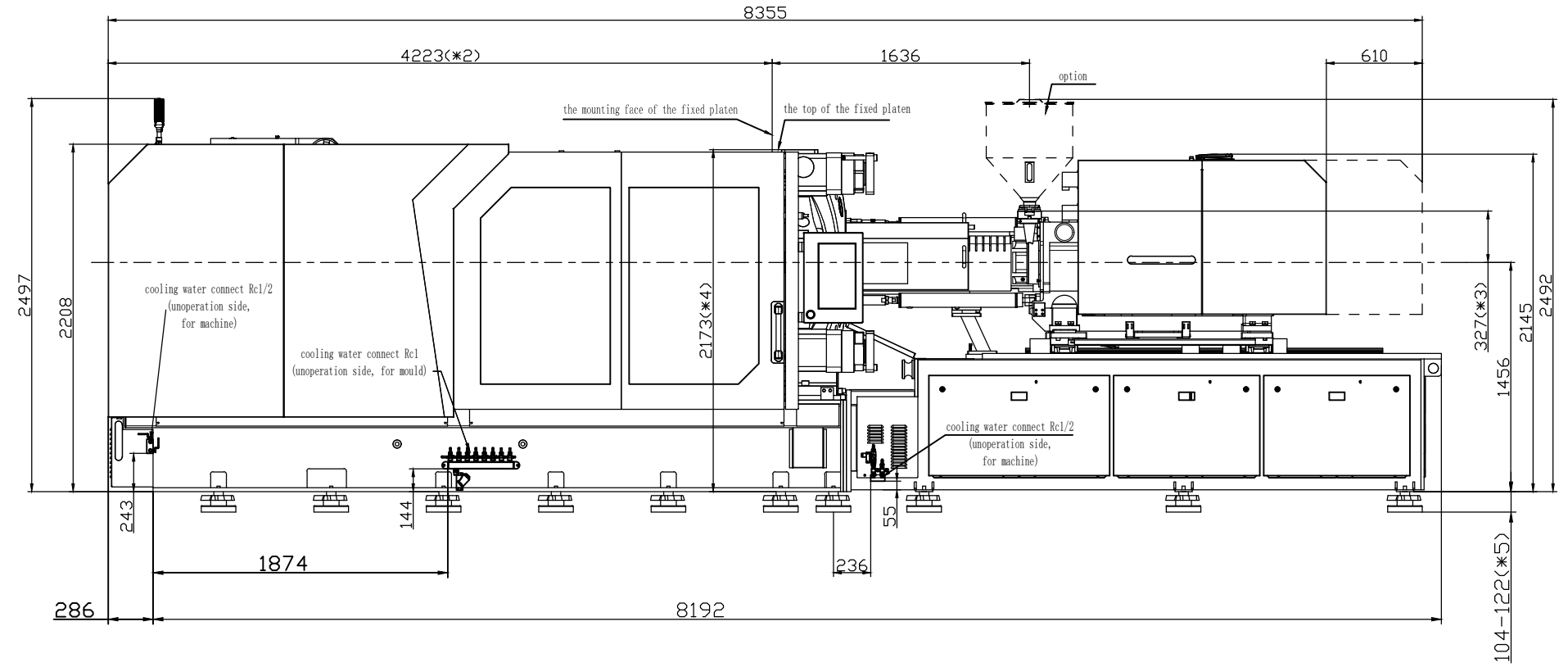
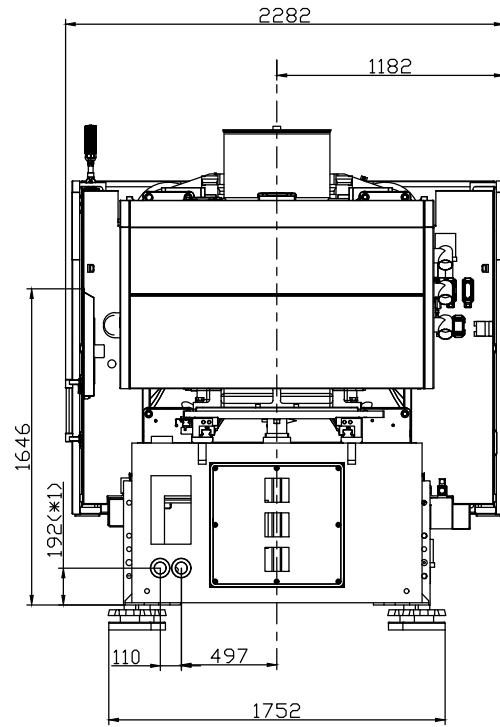

- *1 Power in
Current and Power Cable are shown
in the Main Power Supply Circuit
- *2 To the mounting face of the
fixed platen
- *3 To the face of Hopper fixing platform
- *4 To the top of the fixed platen
- *5 Vibration dumping support



Absolute Haitian Corporation
33 Southgate St. Worcester, MA
T: +1 508-792-4305
www.absolutehaitian.com

Title: ZE V 5500-2250 Layout Drawing

Machine Model: ZE V 5500-2250

Machine Serial Number:

Machine Tonnage:

Sheet: 1 of 1

Drawn By: Harry Date: 3/22/2024

Chkd By: LEON XIE Date: 3/22/2024

NOT TO SCALE Size: 11 X 17 "B"

Units: mm / [in]

Material:

Part:

Part:

Part:

Part:

Part:

PLEASE READ:

The designs on this drawing were validated using machine manufacturer's drawings and/or information supplied by Absolute or the customer. It is the responsibility of the customer to review and confirm that all dimensions are consistent with the application intended and in accordance with the facility requirements for space, part clearance, overhead clearance, or any other interference. By signing this document, the customer accepts full responsibility for this design and application.

Customer:

Customer Approval:

Authorized Signature

Notes:

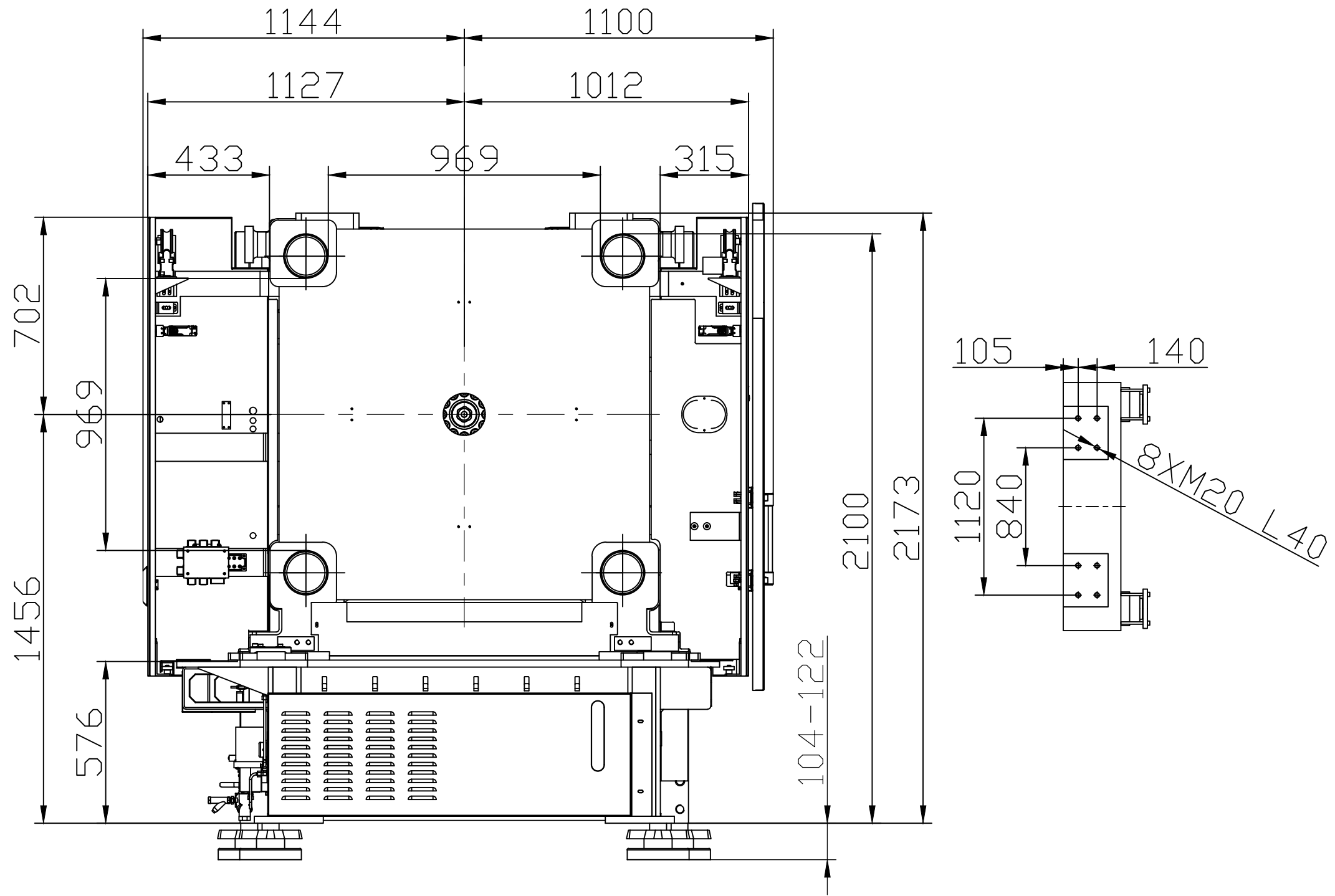

Absolute Haitian Corporation
 33 Southgate St. Worcester, MA
 T:+1 508-792-4305
 www.absolutehaitian.com

Title: ZE V 5500 Robot Mounting Drawing

Machine Model: ZE V 5500
 Machine Serial Number:
 Machine Tonnage:

Sheet: 1 of 1

Drawn By: Harry Date: 4/9/2024
 Chkd By: LEON XIE Date: 4/9/2024

Revision	Date:	Drawing #: Robot Mounting
Rev #: 1		
Rev #: 2		
Rev #: 3		
Rev #: 4		
Rev #: 5		

NOT TO SCALE Size: 11 X 17 "B"

Units: mm / [in]
 Material:
 Part:
 Part:
 Part:
 Part:

PLEASE READ:

The designs on this drawing were validated using machine manufacturer's drawings and/or information supplied by Absolute or the customer. It is the responsibility of the customer to review and confirm that all dimensions are consistent with the application intended and in accordance with the facility requirements for space, part clearance, overhead clearance, or any other interference. By signing this document, the customer accepts full responsibility for this design and application.

Customer:

Customer Approval:
 Authorized Signature

Notes: