

# Specification



## ZE5500V-3350

ZERES 5 Series: Electric with Integrated Hydraulics



Clamping Unit		ZE5500 V
Clamping Force	kN	5500
	US Tons	618
Mold Opening Stroke	mm	900
	in.	35.43
Minimum Mold Height	mm	400
	in.	15.75
Maximum Mold Height	mm	880
	in.	34.65
Maximum Daylight	mm	1780
	in.	70.08
Distance Between Tie-Bars (HXV)	mm	970x970
	in.	38.19x38.19
Platen Dimensions (HXV)	mm	1320x1320
	in.	51.97x51.97
Minimum Mold Size	mm	630x630
	in.	24.8x24.8
Ejector Stroke	mm	180
	in.	7.09
Ejector Force	kN	154
	US Tons	17

# Specification



## ZE5500V-3350

ZERES 5 Series: Electric with Integrated Hydraulics

Injection Unit		3350		
Screw & Barrel Designation		A	B	C
Screw Diameter	mm	75	80	90
	in.	2.95	3.15	3.54
Screw L/D Ratio	L/D	21.3	20	17.8
Injection Volume (Theoretical)	cm <sup>3</sup>	1634	1859	2353
	cu.in.	99.71	113.44	143.59
Injection Weight (PS)	g	1487	1692	2141
	oz.	52.45	59.68	75.52
Injection Pressure	MPa	205	180	142
	psi	29733	26107	20595
Holding Pressure	MPa	185	162	128
	psi	26832	23496	18565
Screw Speed	rpm	220	220	220
Plasticizing Rate (GPPS)	g/s	70	92	105
	oz./s	2.47	3.25	3.70
Nozzle Contact Force	kN	85	85	85
	US Tons	10	10	10
Injection Unit		3350		
Injection Speed	mm/s	160		
	in./s	6.3		
Injection Rate (PS)	g/s	617	702	889
	oz./s	21.76	24.76	31.36

# Specification



## ZE5500V-3350

ZERES 5 Series: Electric with Integrated Hydraulics

Other		
Connection Power	kW/A	83/138
Heating Power	kW	42.6
Machine Dimension	m	8.74x2.29x2.50
	in.	344x90x98
Machine Weight	t	28.64
	lbs.	63140
Hopper Capacity	l	100
	gal	26
Oil Pressure	MPa	17.5
	psi	2538
Oil Flow	l/min	204
	gal/min	54
Oil Tank	l	284
	gal	75

\*NOTE:

1. Machine dimensions and weights are based on the international standard configuration and are for reference only. Any options or country specific requirements will affect this. Contact Absolute Haitian service department for machine specific information.
2. Power requirements are based on the international standard configuration and are for reference only. Any options or country specific requirements will affect this. Contact Absolute Haitian service department for machine specific information.

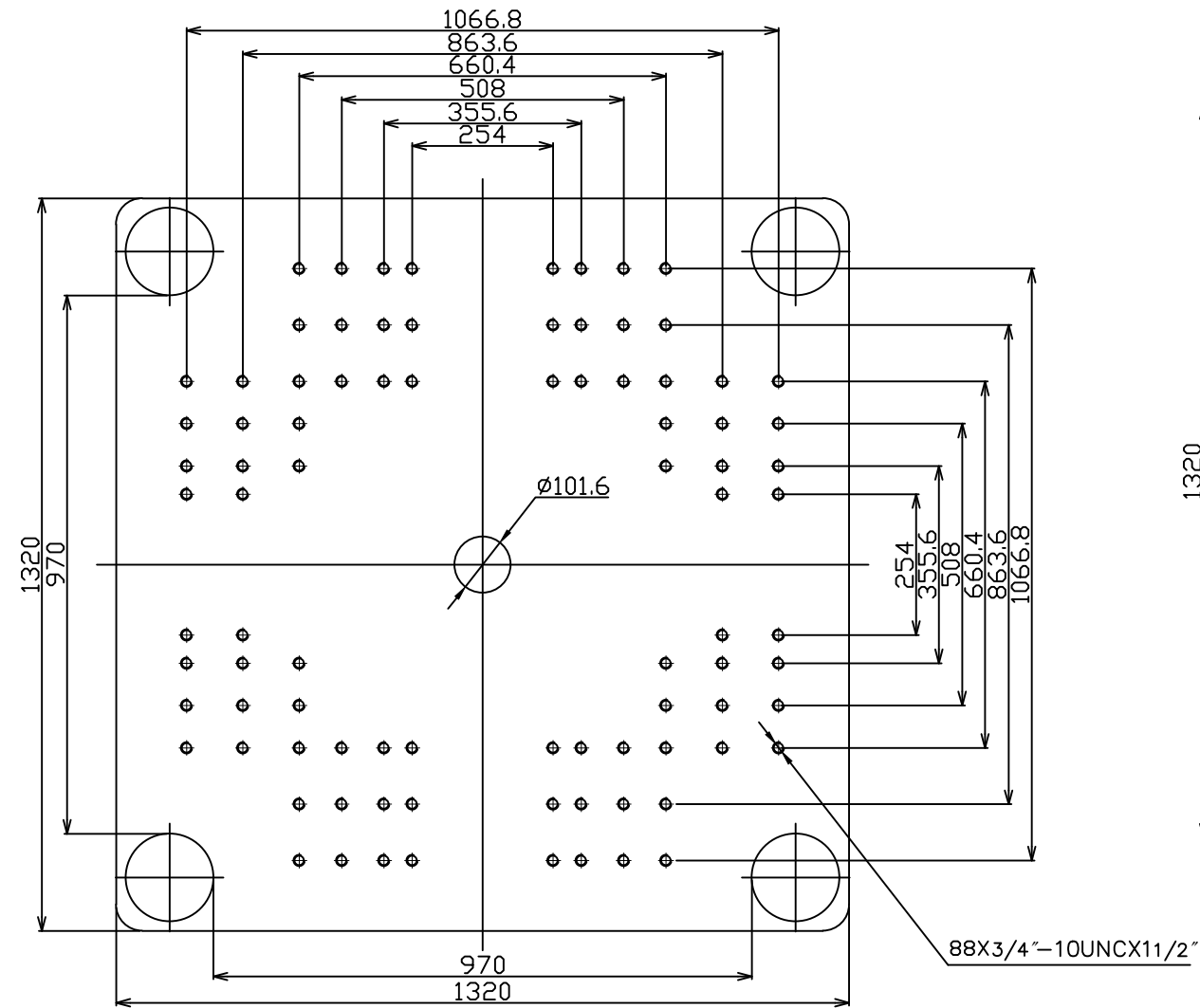

Fixed Platen

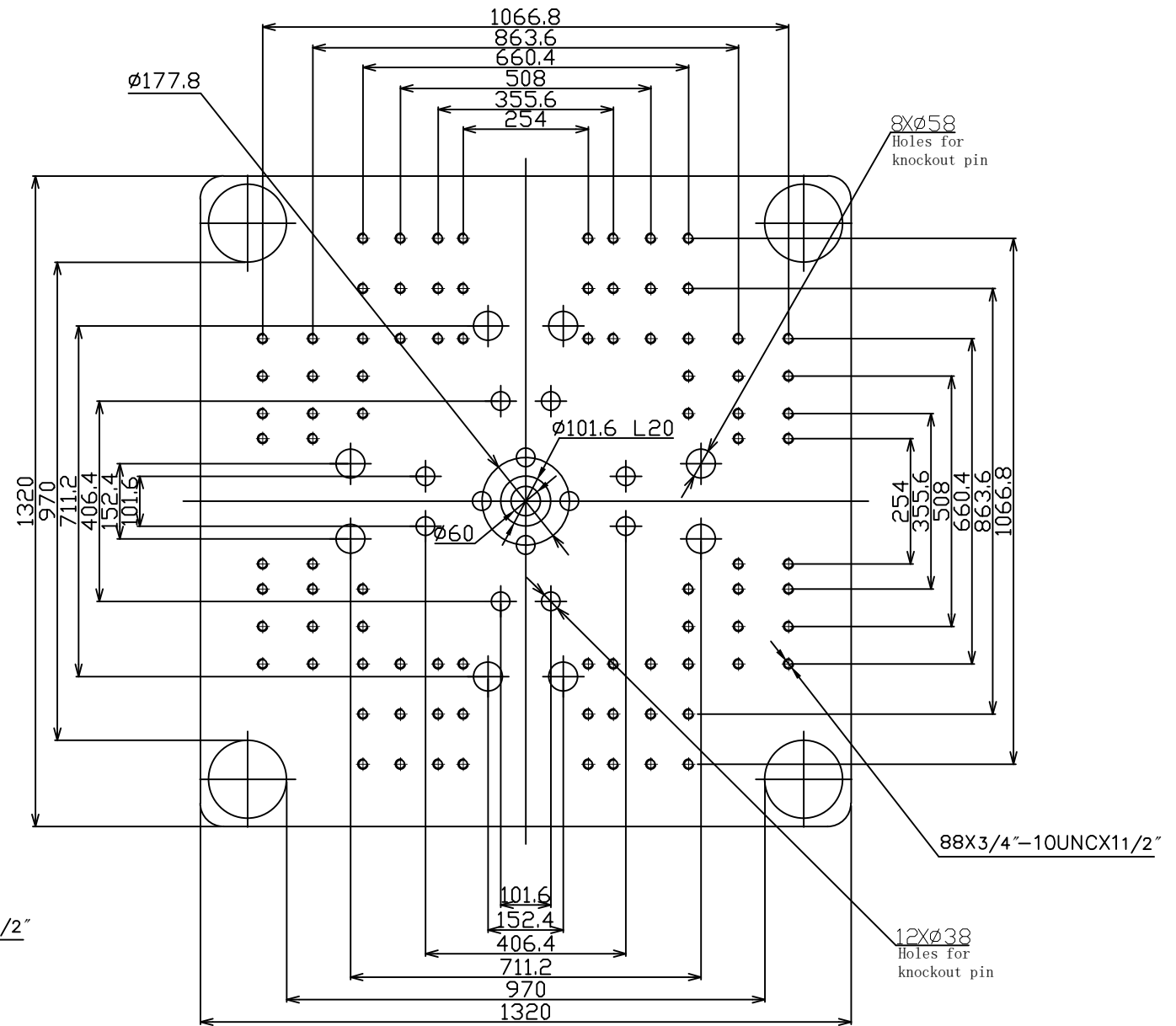

Moving Platen



Absolute Haitian Corporation  
33 Southgate St. Worcester, MA  
T: +1 508-792-4305  
www.absolutehaitian.com

Title: ZE/VEV 5500 Fixed & Moving Platens Drawing

Machine Model: ZE/VEV 5500  
Machine Serial Number:  
Machine Tonnage:

Sheet: 1 of 1

Drawn By: Harry Date: 1/9/2024  
Chkd By: LEON XIE Date: 1/9/2024

Revision	Date:	Drawing #:	NOT TO SCALE	Size: 11 X 17 "B"
Rev #: 1				Units: mm / [in]
Rev #: 2				Material:
Rev #: 3				Part:
Rev #: 4				Part:
Rev #: 5				Part:

PLEASE READ:

The designs on this drawing were validated using machine manufacturer's drawings and/or information supplied by Absolute or the customer. It is the responsibility of the customer to review and confirm that all dimensions are consistent with the application intended and in accordance with the facility requirements for space, part clearance, overhead clearance, or any other interference. By signing this document, the customer accepts full responsibility for this design and application.

Customer:

Customer Approval:  
Authorized Signature

Notes:

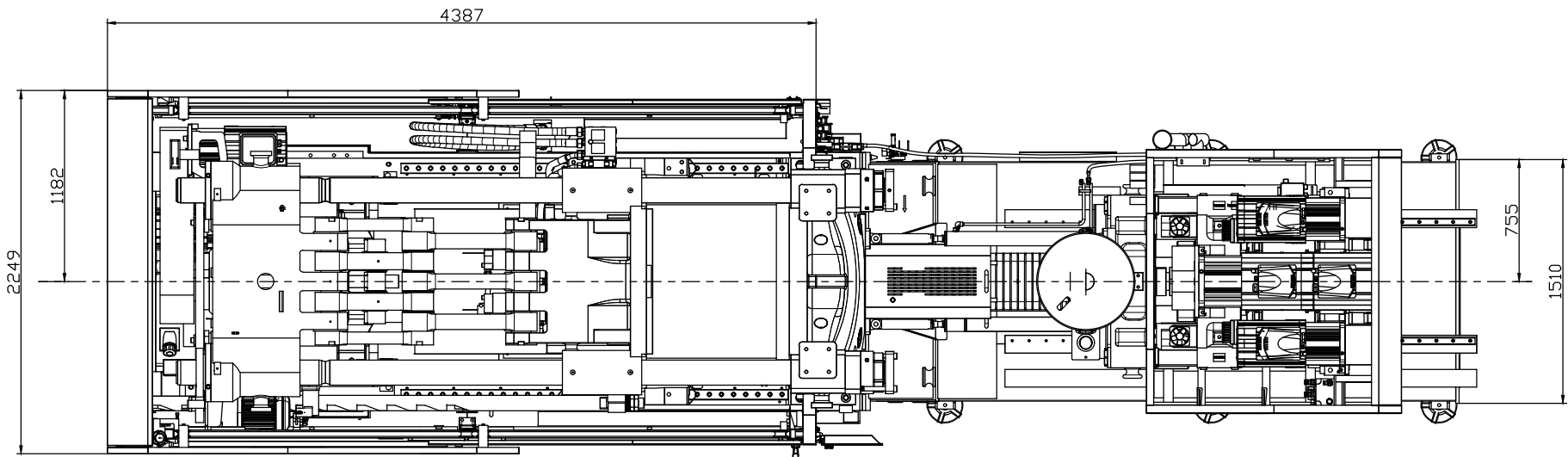
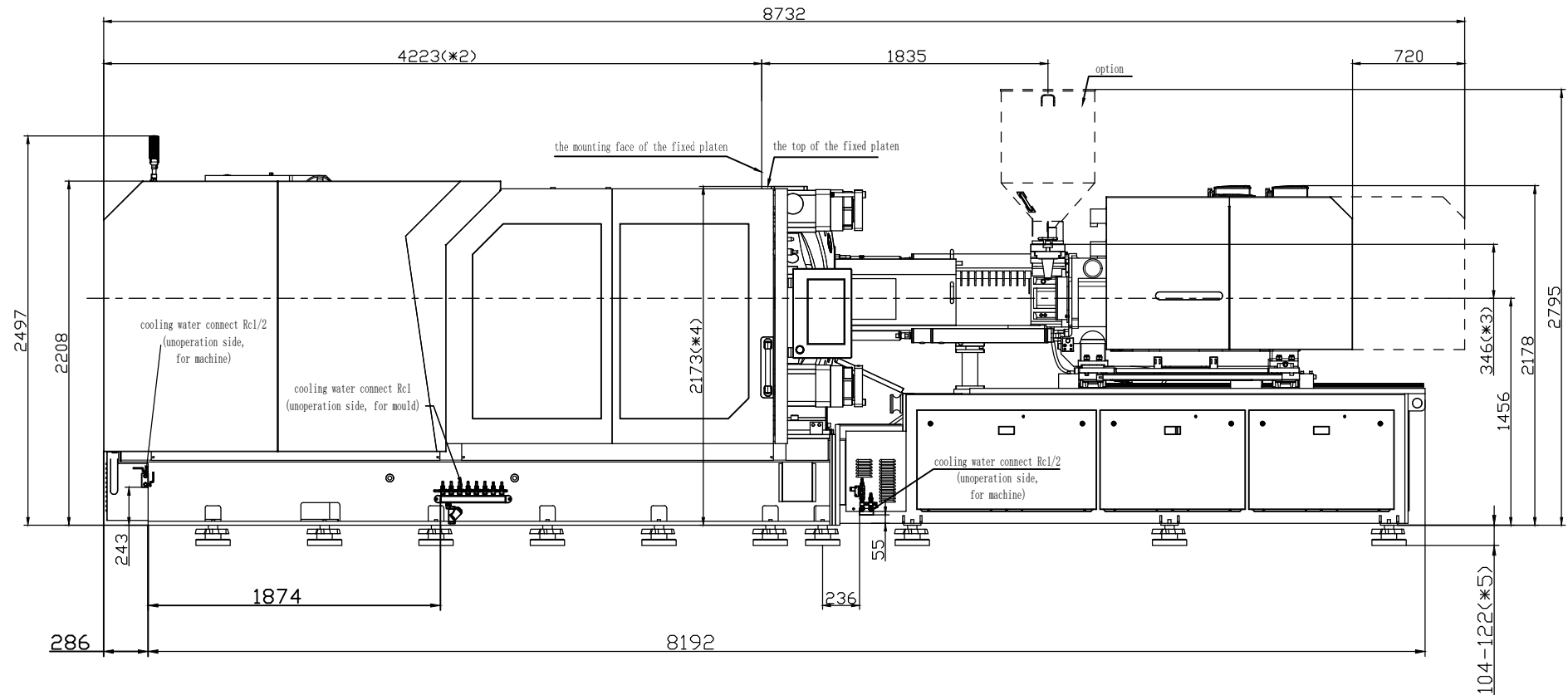
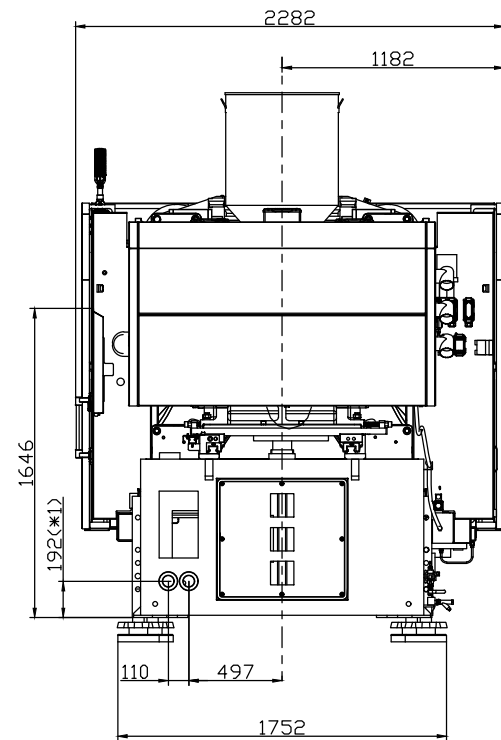

- \*1 Power in Current and Power Cable are shown in the Main Power Supply Circuit
- \*2 To the mounting face of the fixed platen
- \*3 To the face of Hopper fixing platform
- \*4 To the top of the fixed platen
- \*5 Vibration dumping support



Absolute Haitian Corporation  
33 Southgate St. Worcester, MA  
T:+1 508-792-4305  
www.absolutehaitian.com

Title: ZE V 5500-3350 Layout Drawing

Machine Model: ZE V 5500-3350

Machine Serial Number:

Machine Tonnage:

Sheet: 1 of 1

Drawn By: Harry

Date: 3/22/2024

Chkd By: LEON XIE

Date: 3/22/2024

NOT TO SCALE Size: 11 X 17 "B"

Revision	Date:	Drawing #: Layout
Rev #: 1		
Rev #: 2		
Rev #: 3		
Rev #: 4		
Rev #: 5		

Units: mm / [in]

Material:

Part:

Part:

Part:

Part:

Part:

PLEASE READ:

The designs on this drawing were validated using machine manufacturer's drawings and/or information supplied by Absolute or the customer. It is the responsibility of the customer to review and confirm that all dimensions are consistent with the application intended and in accordance with the facility requirements for space, part clearance, overhead clearance, or any other interference. By signing this document, the customer accepts full responsibility for this design and application.

Customer:

Customer Approval:

Authorized Signature

Notes:

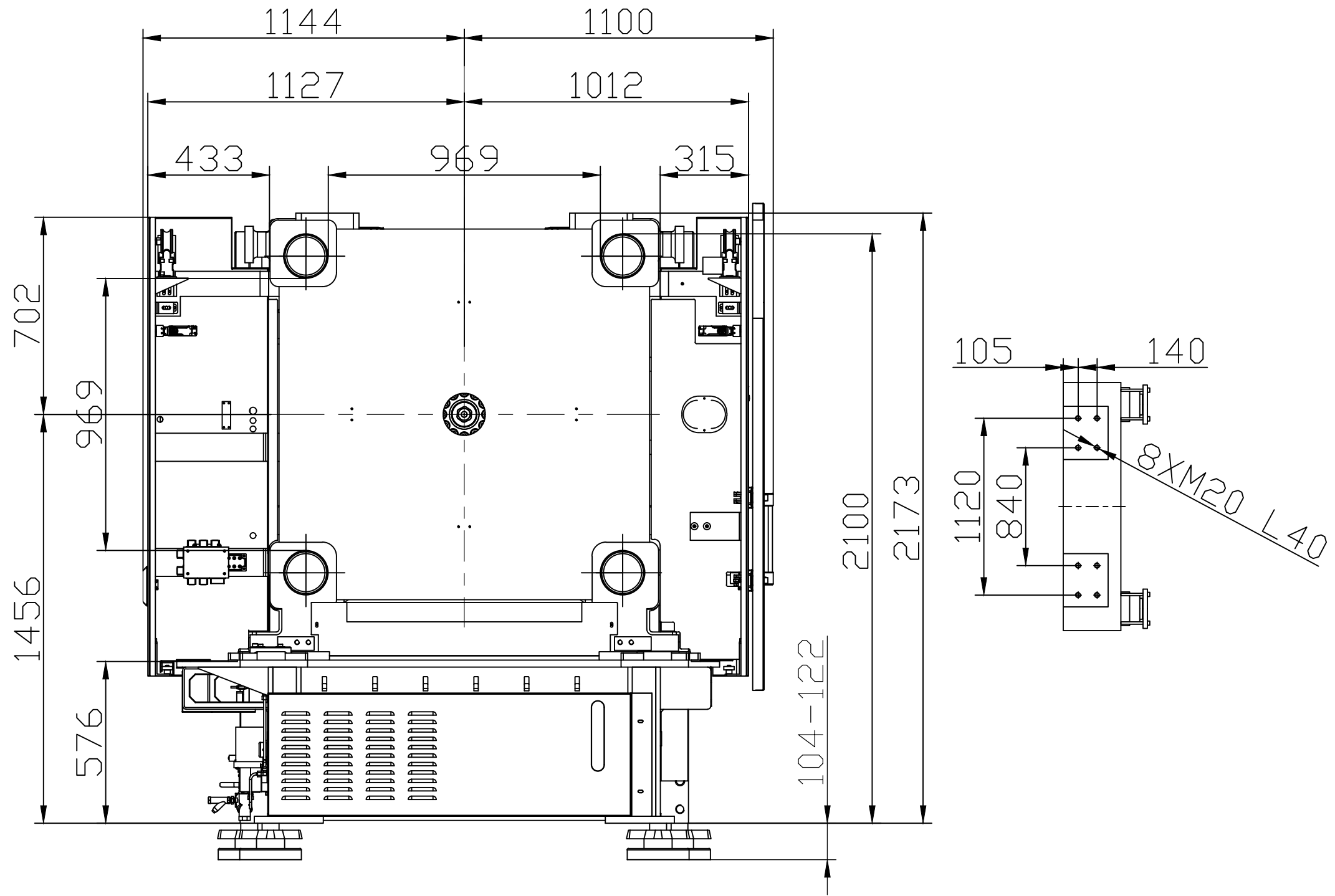

Absolute Haitian Corporation  
 33 Southgate St. Worcester, MA  
 T:+1 508-792-4305  
 www.absolutehaitian.com

Title: ZE V 5500 Robot Mounting Drawing

Machine Model: ZE V 5500  
 Machine Serial Number:  
 Machine Tonnage:

Sheet: 1 of 1

Drawn By: Harry Date: 4/9/2024  
 Chkd By: LEON XIE Date: 4/9/2024

Revision Date: Drawing #: Robot Mounting

Rev #: 1  
 Rev #: 2  
 Rev #: 3  
 Rev #: 4  
 Rev #: 5

NOT TO SCALE Size: 11 X 17 "B"

Units: mm / [in]  
 Material:  
 Part:  
 Part:  
 Part:  
 Part:

PLEASE READ:

The designs on this drawing were validated using machine manufacturer's drawings and/or information supplied by Absolute or the customer. It is the responsibility of the customer to review and confirm that all dimensions are consistent with the application intended and in accordance with the facility requirements for space, part clearance, overhead clearance, or any other interference. By signing this document, the customer accepts full responsibility for this design and application.

Customer:

Customer Approval:  
 Authorized Signature

Notes: