

Specification



ZE1900V-640

ZERES 5 Series: Electric with Integrated Hydraulics



Clamping Unit		ZE1900 V
Clamping Force	kN	1900
	US Tons	214
Mold Opening Stroke	mm	470
	in.	18.5
Minimum Mold Height	mm	200
	in.	7.87
Maximum Mold Height	mm	550
	in.	21.65
Maximum Daylight	mm	1020
	in.	40.16
Distance Between Tie-Bars (HXV)	mm	570x570
	in.	22.44x22.44
Platen Dimensions (HXV)	mm	800x800
	in.	31.5x31.5
Minimum Mold Size	mm	370x370
	in.	14.57x14.57
Ejector Stroke	mm	130
	in.	5.12
Ejector Force	kN	55
	US Tons	6

Specification



ZE1900V-640

ZERES 5 Series: Electric with Integrated Hydraulics

Injection Unit		640		
Screw & Barrel Designation		A	B	C
Screw Diameter	mm	40	45	50
	in.	1.57	1.77	1.97
Screw L/D Ratio	L/D	22.5	20	18
Injection Volume (Theoretical)	cm ³	252	319	394
	cu.in.	15.38	19.47	24.04
Injection Weight (PS)	g	229	290	358
	oz.	8.08	10.23	12.63
Injection Pressure	MPa	253	200	162
	psi	36695	29008	23496
Holding Pressure	MPa	202	160	130
	psi	29298	23206	18855
Screw Speed	rpm	350	350	350
Plasticizing Rate (GPPS)	g/s	27	39	50
	oz./s	0.95	1.38	1.76
Nozzle Contact Force	kN	65	65	65
	US Tons	7	7	7
Injection Unit		640		
Injection Speed	mm/s	160		
	in./s	6.3		
Injection Rate (PS)	g/s	175	222	274
	oz./s	6.17	7.83	9.67
Injection Unit		640h		
Injection Speed	mm/s	250		
	in./s	9.84		
Injection Rate (PS)	g/s	274	347	428
	oz./s	9.67	12.24	15.10
Injection Unit		640hs		
Injection Speed	mm/s	350		
	in./s	13.78		
Injection Rate (PS)	g/s	384	486	600
	oz./s	13.55	17.14	21.16

Specification



ZE1900V-640

ZERES 5 Series: Electric with Integrated Hydraulics

Other		
Connection Power	kW/A	640:28/47 640h:32/53 640hs:49/82
Heating Power	kW	14.8
Machine Dimension	m in.	5.99x1.52x2.29 236x60x90
Machine Weight	t lbs.	7.9 17417
Hopper Capacity	l gal	25 7
Oil Pressure	MPa psi	17.5 2538
Oil Flow	l/min gal/min	79 21
Oil Tank	l gal	107 28

***NOTE:**

1. Machine dimensions and weights are based on the international standard configuration and are for reference only. Any options or country specific requirements will affect this. Contact Absolute Haitian service department for machine specific information.
2. Power requirements are based on the international standard configuration and are for reference only. Any options or country specific requirements will affect this. Contact Absolute Haitian service department for machine specific information.

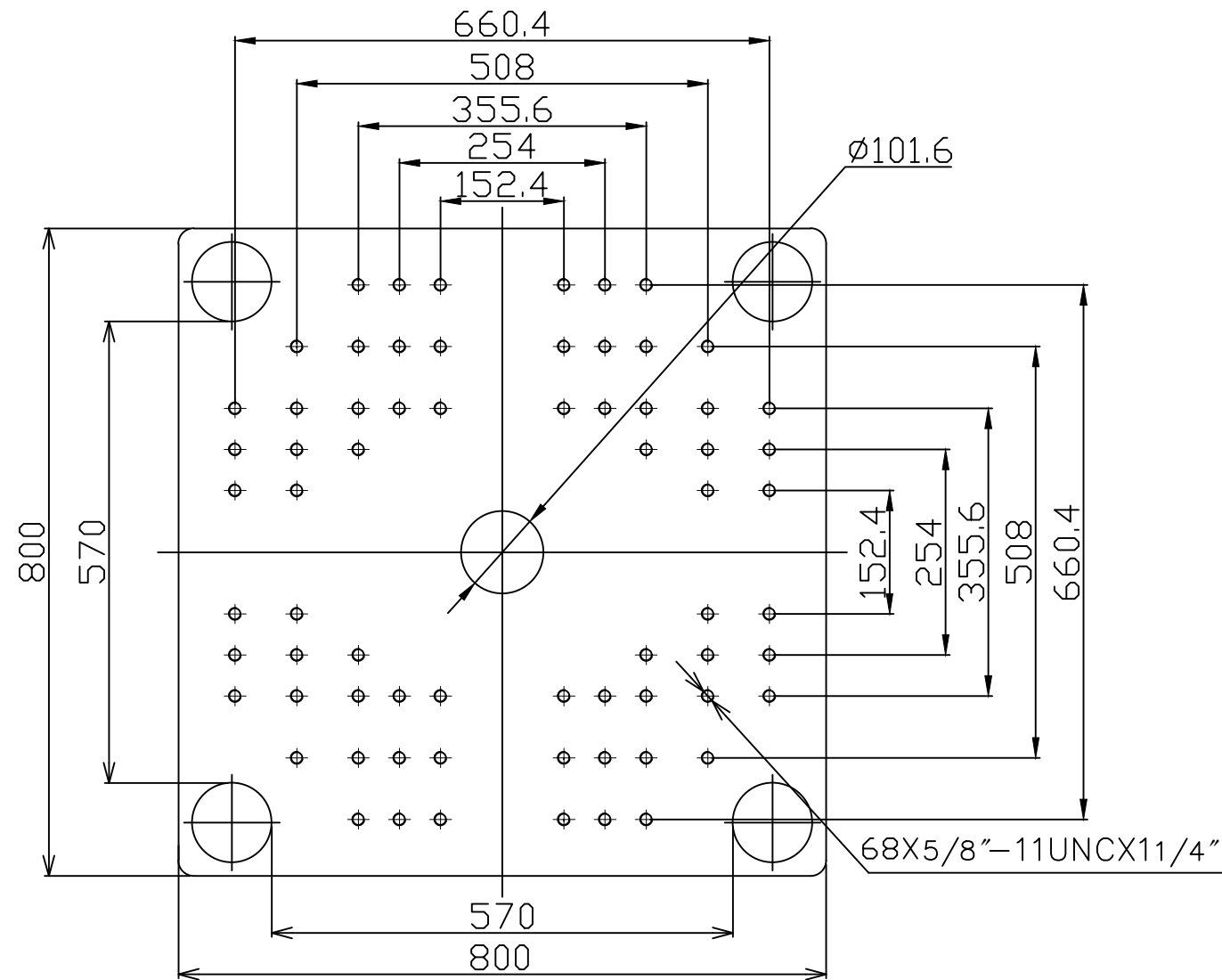

Fixed Platen

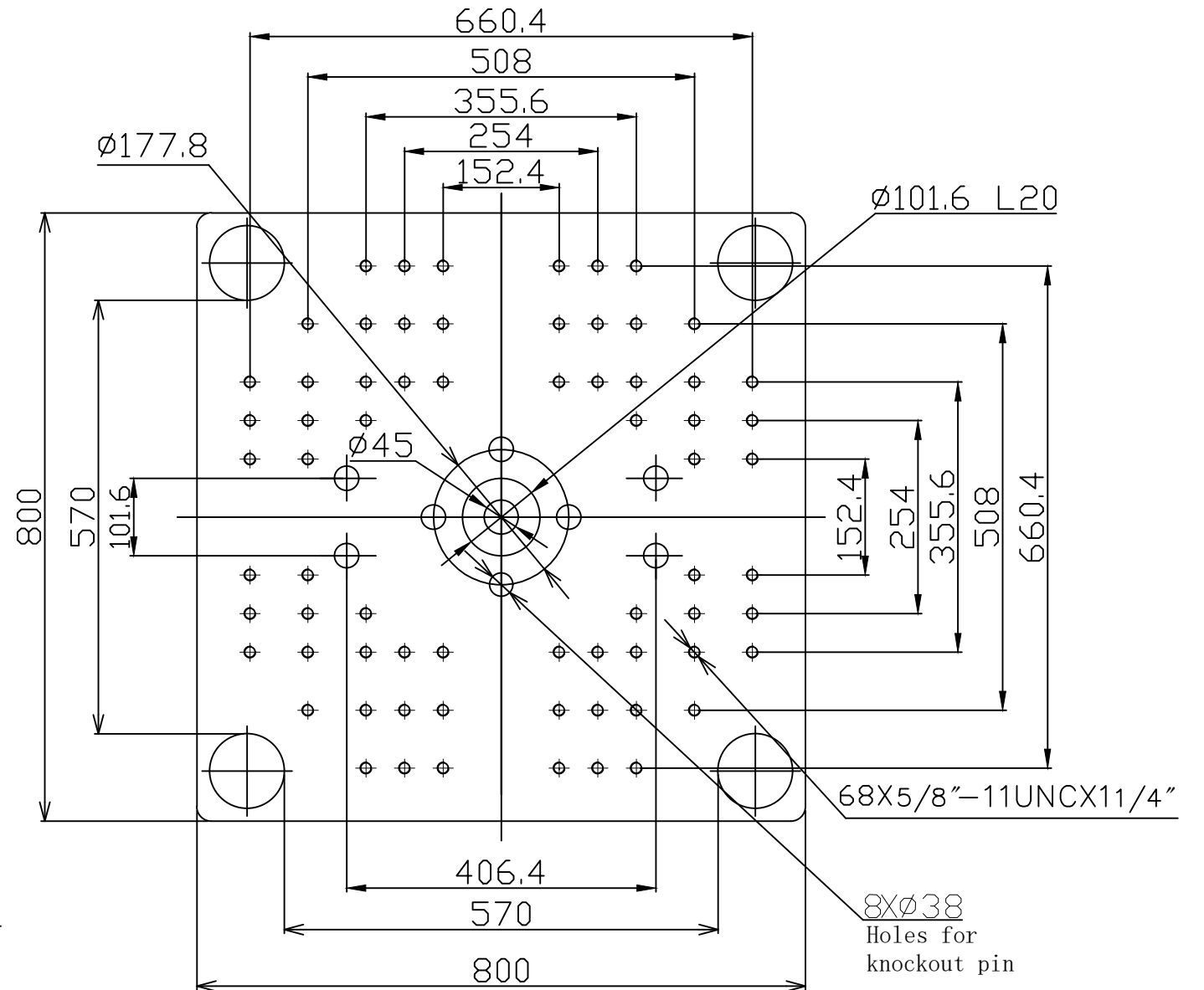

Moving Platen



Absolute Haitian Corporation
33 Southgate St. Worcester, MA
T: +1 508-792-4305
www.absolutehaitian.com

Title: ZE/VEV 1900 Fixed & Moving Platens Drawing

Machine Model: ZE/VEV 1900
Machine Serial Number:
Machine Tonnage:

Sheet: 1 of 1

Drawn By: Harry Date: 1/9/2024
Chkd By: LEON XIE Date: 1/9/2024

Revision	Date:	Drawing #:	NOT TO SCALE	Size: 11 X 17 "B"
Rev #: 1				Units: mm / [in]
Rev #: 2				Material:
Rev #: 3				Part:
Rev #: 4				Part:
Rev #: 5				Part:

PLEASE READ:

The designs on this drawing were validated using machine manufacturer's drawings and/or information supplied by Absolute or the customer. It is the responsibility of the customer to review and confirm that all dimensions are consistent with the application intended and in accordance with the facility requirements for space, part clearance, overhead clearance, or any other interference. By signing this document, the customer accepts full responsibility for this design and application.

Customer:

Customer Approval:
Authorized Signature

Notes:

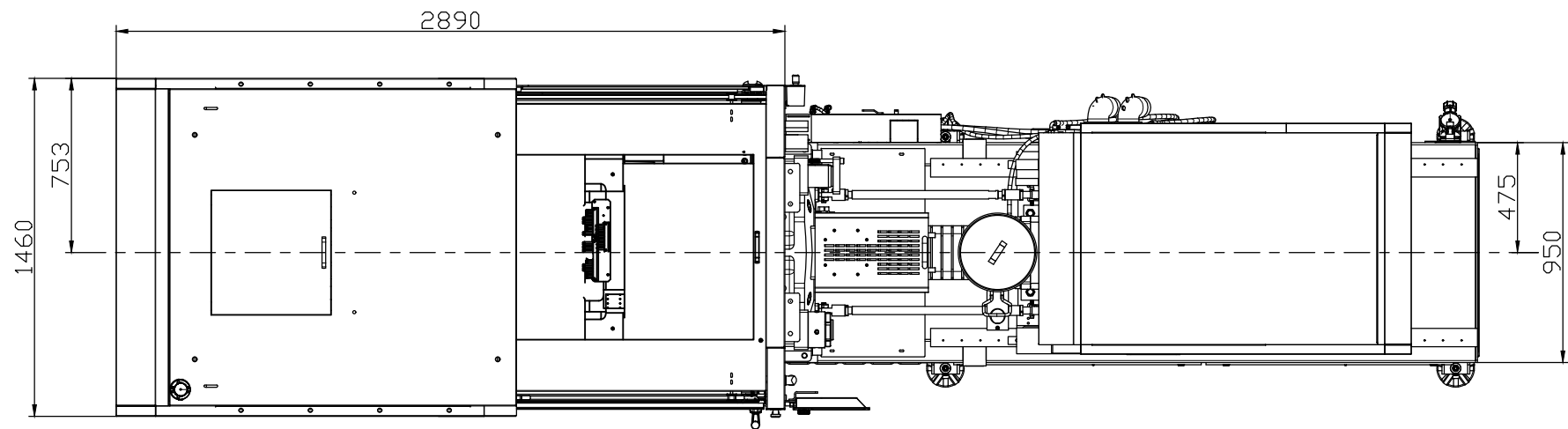
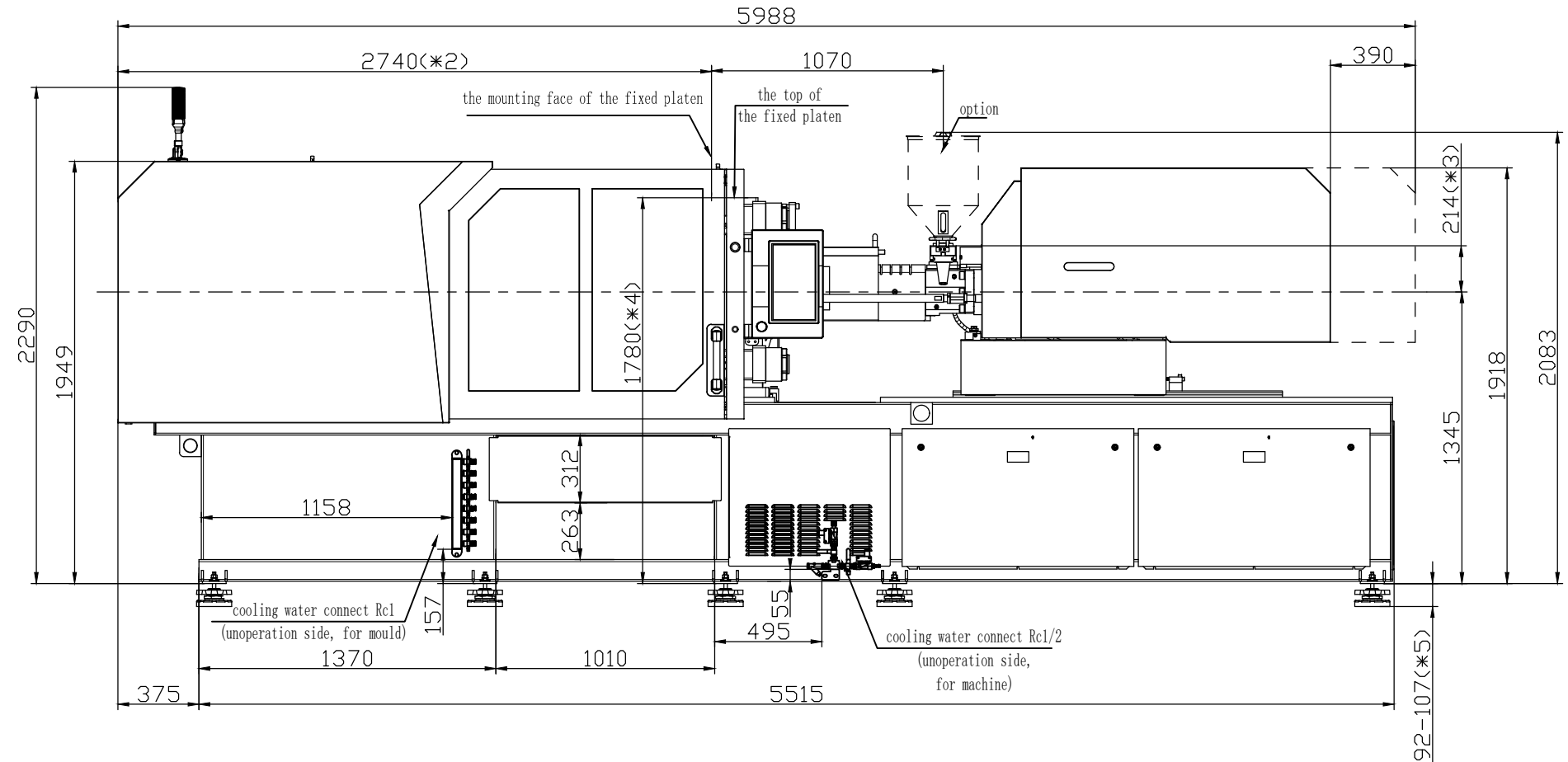
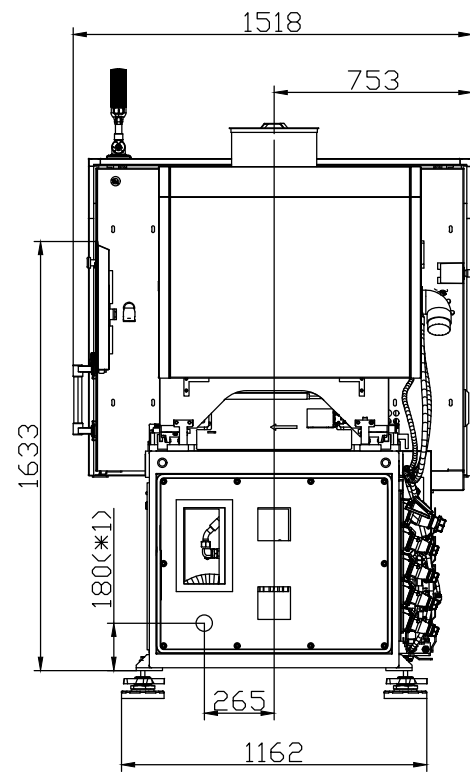

- *1 Power in
Current and Power Cable are shown in the Main Power Supply Circuit
- *2 To the mounting face of the fixed platen
- *3 To the face of Hopper fixing platform
- *4 To the top of the fixed platen
- *5 Vibration dumping support



Absolute Haitian Corporation
33 Southgate St. Worcester, MA
T:+1 508-792-4305
www.absolutehaitian.com

Title: ZE V 1900-640 Layout Drawing

Machine Model: ZE V 1900-640

Machine Serial Number:

Machine Tonnage:

Sheet: 1 of 1

Drawn By: Harry Date: 3/22/2024

Chkd By: LEON XIE Date: 3/22/2024

Revision Date: Drawing #: Layout

Rev #: 1

Rev #: 2

Rev #: 3

Rev #: 4

Rev #: 5

NOT TO SCALE Size: 11 X 17 "B"

Units: mm / [in]

Material:

Part:

Part:

Part:

Part:

PLEASE READ:

The designs on this drawing were validated using machine manufacturer's drawings and/or information supplied by Absolute or the customer. It is the responsibility of the customer to review and confirm that all dimensions are consistent with the application intended and in accordance with the facility requirements for space, part clearance, overhead clearance, or any other interference. By signing this document, the customer accepts full responsibility for this design and application.

Customer:

Customer Approval:

Authorized Signature

Notes:

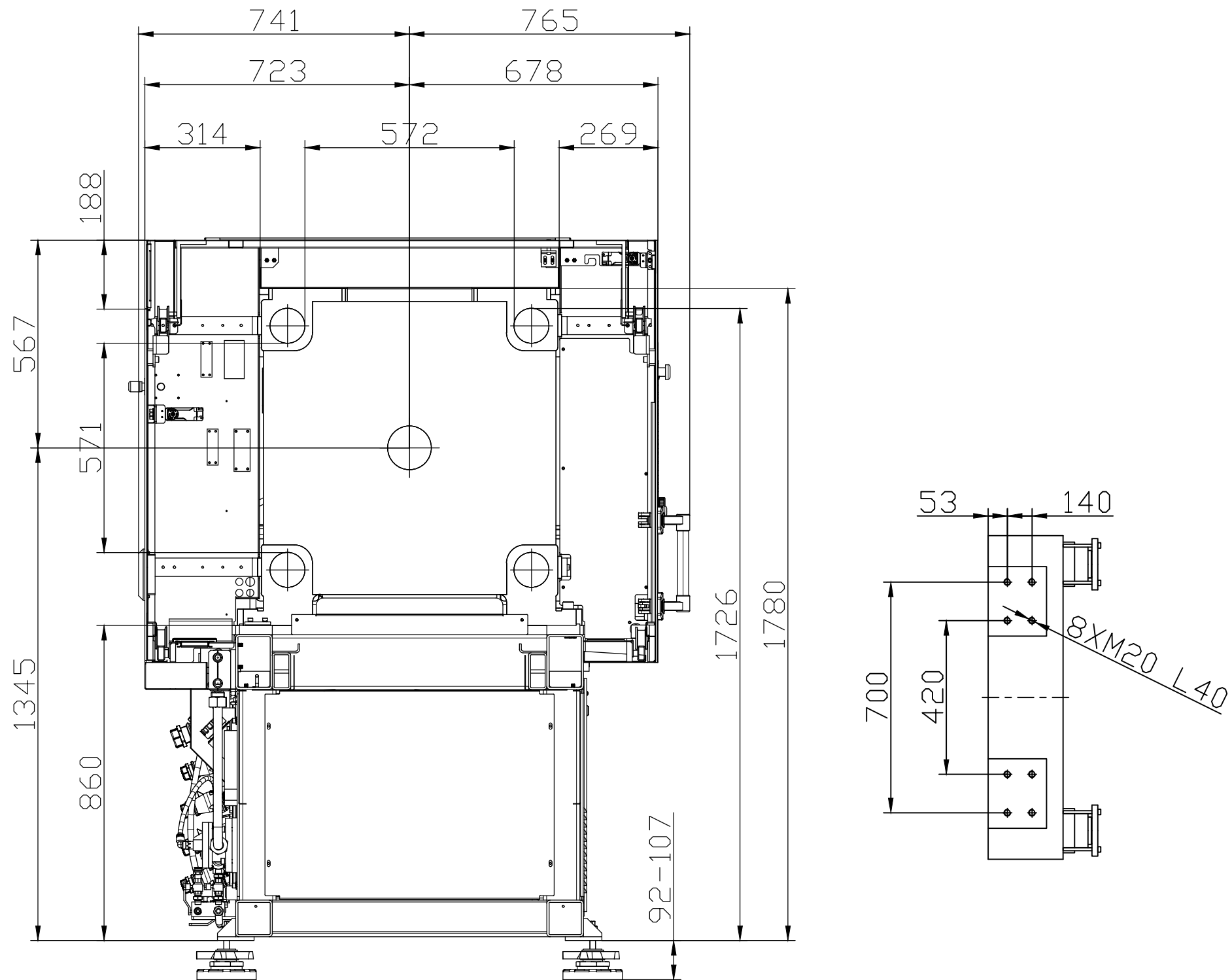

Absolute Haitian Corporation
 33 Southgate St. Worcester, MA
 T:+1 508-792-4305
 www.absolutehaitian.com

Title: ZE V 1900 Robot Mounting Drawing

Machine Model: ZE V 1900
 Machine Serial Number:
 Machine Tonnage:

Sheet: 1 of 1

Drawn By: Harry Date: 4/9/2024
 Chkd By: LEON XIE Date: 4/9/2024

Revision Date: Drawing #: Robot Mounting

Rev #: 1
 Rev #: 2
 Rev #: 3
 Rev #: 4
 Rev #: 5

NOT TO SCALE Size: 11 X 17 "B"

Units: mm / [in]
 Material:
 Part:
 Part:
 Part:
 Part:

PLEASE READ:

The designs on this drawing were validated using machine manufacturer's drawings and/or information supplied by Absolute or the customer. It is the responsibility of the customer to review and confirm that all dimensions are consistent with the application intended and in accordance with the facility requirements for space, part clearance, overhead clearance, or any other interference. By signing this document, the customer accepts full responsibility for this design and application.

Customer:

Customer Approval:
 Authorized Signature

Notes: